

NORBIT - iWBMS_e Stabilised Long Range

Compact High-Resolution Integrated and Motion Stabilised 3D&4D Shallow Water Bathymetric System.

This cylindrical high-resolution curved array bathymetric system is designed to function effectively in extreme operational environments with high vessel motion.

It offers rapid mobilisation at any location and time, providing active roll, pitch and yaw stabilised bathymetry.

Additionally, it delivers standard imagery and backscatter outputs, ensuring the highest quality survey data performance.

The small system form factor, low power consumption, and tight integration enable installation on various survey platforms such as USVs, pole mounts, and vessel hull mounting configurations.

The system supports native data collection by DCT NORBIT data acquisition software for sonar and GNSS/INS data files.



Features

- ✓ Multibeam Sonar with Integrated Inertial Navigation System & Integrated NTRIP Client.
- ✓ 80kHz Bandwidth
- ✓ Active Roll, Pitch & Yaw (Option) Stabilisation
- ✓ Backscatter outputs (Intensity, Sidescan, Snippets, Water Column)
- ✓ Multidetector
- ✓ Simple Ethernet Interface
- ✓ Integrated Sound Velocity Probe
- ✓ Hydrodynamic Fairing
- ✓ FM & CW Processing
- ✓ Exceeds IHO Exclusive Order & USACE New Work

Options

- ✓ Yaw Stabilisation w. Single Head
- ✓ Dual Swath with 2048 Dynamically Focused Beams (Single Head)
- ✓ Hull and Pole Mount Options
- ✓ Backscattering Strength Output
- ✓ Acquisition, Navigation and Post Processing Software
- ✓ Senior Hydrographer for Support and Training
- ✓ Can be Delivered with Software Packages e.g. DCT, HYPACK, Qinsy, EIVA, CARIS, BeamworX and Others

Applications

- ✓ Coastal Zone and Offshore Bathymetry
- ✓ Pipeline Surveys
- ✓ Pond, River and Estuary Surveys
- ✓ Harbor and Lake Surveys
- ✓ Dredging
- ✓ Windfarm Surveys
- ✓ High Speed Surveys
- ✓ USV & UUV Ready

NORBIT - iWBMS_e Stabilised Long Range

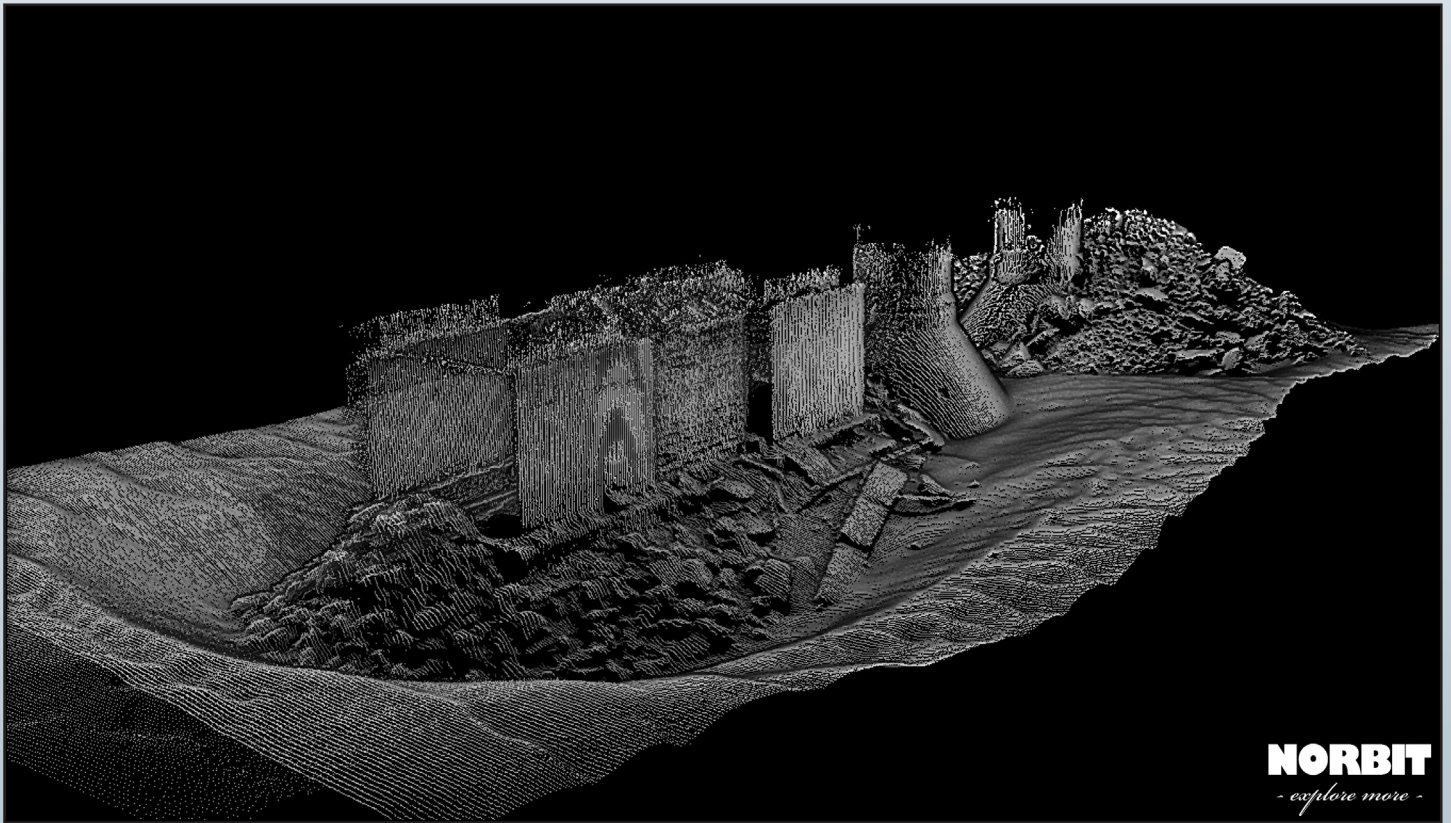

TECHNICAL SPECIFICATION

| | |
|--------------------------------|---|
| SWATH COVERAGE | 5-210° FLEXIBLE SECTOR (SHALLOW WATER IHO SPECIAL ORDER >155°) |
| RANGE RESOLUTION | <10mm ACOUSTIC W. 80kHz BANDWIDTH |
| NUMBER OF BEAMS | EA & ED: 256, 512, 1024 (2048 OPTION) |
| OPERATING FREQUENCY | NOMINAL FREQUENCY 200kHz & 400kHz (FREQUENCY AGILITY 200-700kHz) |
| DEPTH RANGE | 0.2-550m |
| PING RATE | UP TO 60Hz, ADAPTIVE |
| RESOLUTION (ACROSS X ALONG) | 0.9° X 0.9° @400kHz AND 1.8° X 1.8° @200kHz |
| POSITION | HOR: ±(8mm +1ppm X DISTANCE FROM RTK STATION) VER: ±(15mm +1ppm X DISTANCE FROM RTK STATION) (ASSUMES 1m GNSS SEPARATION) |
| HEADING ACCURACY | 0.08° (RTK) WITH 2m ANTENNA SEPARATION |
| PITCH/ROLL ACCURACY | 0.03° INDEPENDENT OF ANTENNA SEPARATION |
| HEAVE ACCURACY | 2 cm OR 2% (TRUEHEAVE™), 5 cm OR 5% (REAL TIME) |
| WEIGHT | 7.3kg (AIR), 3.5kg (WATER) WITHOUT BRACKET |
| INTERFACE | ETHERNET |
| CABLE LENGTH | STD: 8m, OPTIONS: 2m, 25m AND 50m |
| POWER CONSUMPTION | 60W (10-28VDC, 110-240VAC) |
| OPERATING TEMP. | -4°C to +40°C (TOPSIDE -20°C to +55°C) |
| STORAGE TEMP. | -20°C TO +60°C |
| ENVIRONMENTAL | TOPSIDE: IP67: DUST TIGHT, PROTECTED AGAINST THE EFFECT OF IMMERSION UP TO 1m/WET-END (SONAR): 100m |

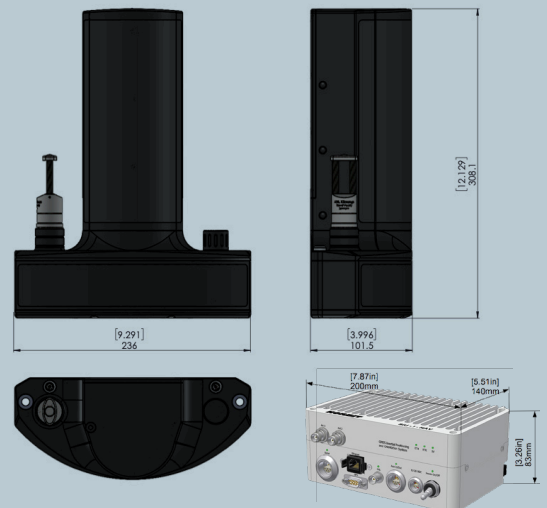

Sonar shown without mounting bracket

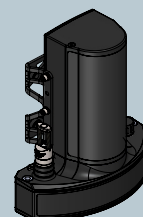

Sonar incl. mounting bracket