

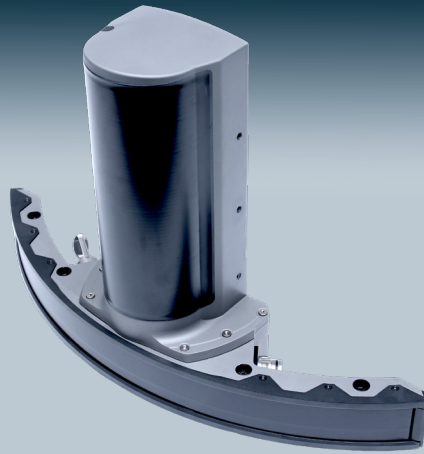

NORBIT WINGHEAD® B41 Titanium



Ultra High-Resolution Curved Array Bathymetric System.

NORBIT introduces the first cylindrical ultra-high resolution curved array bathymetric system, designed for rapid anywhere anytime mobilisation.

The WINGHEAD series are the most compact sonars designed for use on all platforms including subsea ROVs and AUVs. With low power consumption, the system is suitable to operate from battery. NORBIT's wideband multibeam technology facilitates long range real-time data collection and at the same time achieves high resolution data.

The WINGHEAD sonars are based on a state of the art analogue and digital platform featuring powerful signal processing capabilities, offering roll stabilised bathymetry and several types of imagery and backscatter output. With broad R&D expertise, NORBIT has developed, from the ground-up, exciting new technology that allows existing and new applications to benefit from the advantages offered by a compact wideband curved-array multibeam sonar.

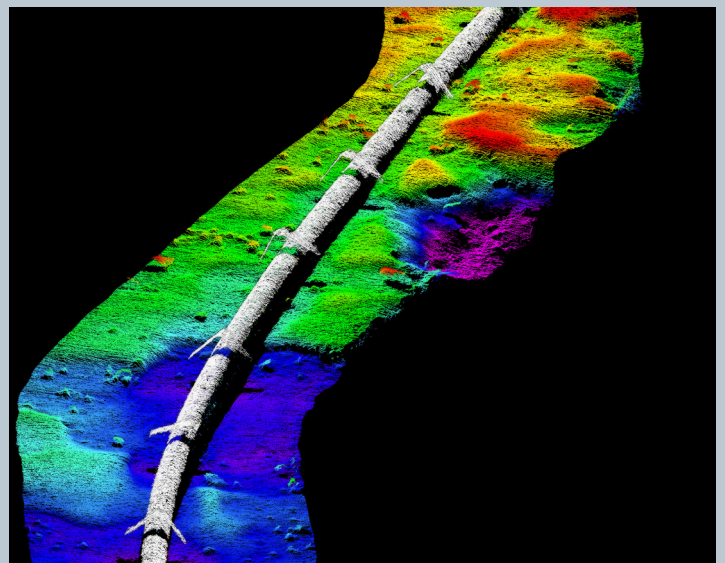
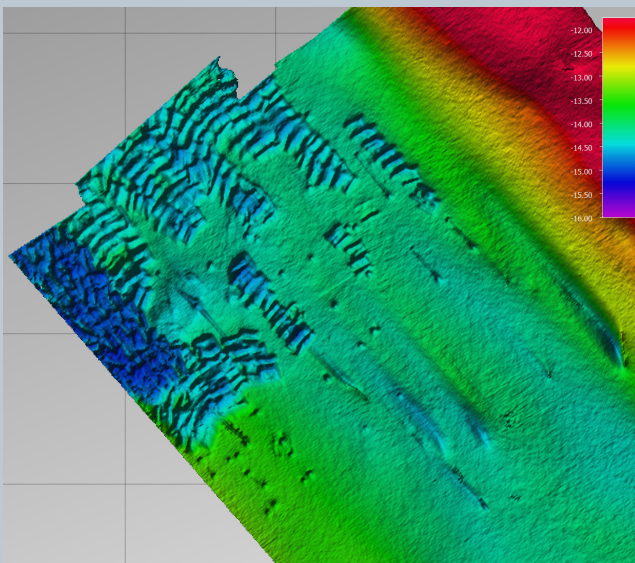



WINGHEAD B41 Titanium

NORBIT
- explore more -

Features	Options	Applications
<ul style="list-style-type: none"> ✓ 80kHz Bandwidth ✓ Roll-stabilisation ✓ Backscatter outputs (Intensity, Sidescan, Snippets, Water Column) ✓ Multidetect ✓ Simple Ethernet Interface ✓ Integrated Sound Velocity Probe ✓ 1024 Dynamically Focused Beams ✓ FM & CW Processing ✓ Incl. Bench Test SIU ✓ Flexible Power ✓ Exceeds IHO Exclusive Order & USACE New Work 	<ul style="list-style-type: none"> ✓ Sound Velocity Profiler ✓ Turnkey Survey Solutions ✓ Permanent Hull Mount Option ✓ Pole Mount Option ✓ Acquisition, Navigation and Post Processing Software ✓ 1500m Depth Rating (WINGHEAD B43) ✓ 4500m Depth Rating (WINGHEAD B44 Deep Sea) ✓ 6000m Depth Rating (WINGHEAD B44 Full ocean) ✓ Mounting Bracket ✓ Can be Delivered with Software Packages e.g. HYPACK, Qinsy, EIVA, CARIS, BeamworX and Others 	<ul style="list-style-type: none"> ✓ Shallow Water Bathymetry ✓ Pipeline & Cable Inspection Surveys ✓ Quay wall, bridge and structure inspection surveys ✓ Pond, River and Estuary Surveys ✓ Harbor and Lake Surveys ✓ USV, UUV, AUV & ROV ✓ Coastal Surveys

TECHNICAL SPECIFICATION

SWATH COVERAGE	5-210° FLEXIBLE SECTOR (SHALLOW WATER IHO SPECIAL ORDER >155°)
RANGE RESOLUTION	<6mm ACOUSTIC w. 80kHz BANDWIDTH
NUMBER OF BEAMS	256, 512, 1024 EA & ED
OPERATING FREQUENCY	NOMINAL FREQUENCY 400kHz (FREQUENCY AGILITY 200-700kHz)
DEPTH RANGE	0.2m to >500m
PING RATE	UP TO 60Hz, ADAPTIVE
RESOLUTION (ACROSS X ALONG)	STANDARD: 0.5° X 0.9° @400kHz, 0.3° x 0.5°@700kHz
INTERFACE	ETHERNET
POWER CONSUMPTION	75W (10-28VDC, 110-240VAC)
DEPTH RATING	100m
DIMENSIONS	DIMENSIONS WITHOUT BRACKET L: 447mm/17.605", H: 296mm/11.657", W: 101.9mm/4.010"
WEIGHT	9.0kg (AIR) 5.9kg (WATER) EXCL. BRACKET 9.5 kg (AIR) 6.3kg (WATER) INCL. BRACKET
CABLE LENGTH	STD: 2m pigtail for ROV/AUV, OPT: 8m, 25m
OPERATING TEMP.	-4°C to +40°C (TOPSIDE -20°C to +55°C)
STORAGE TEMP.	-20°C to +60°C
ENVIRONMENTAL	TOPSIDE: IP67: DUST TIGHT, PROTECTED AGAINST THE EFFECT OF IMMERSION UP TO 1m

OUTLINE DRAWING

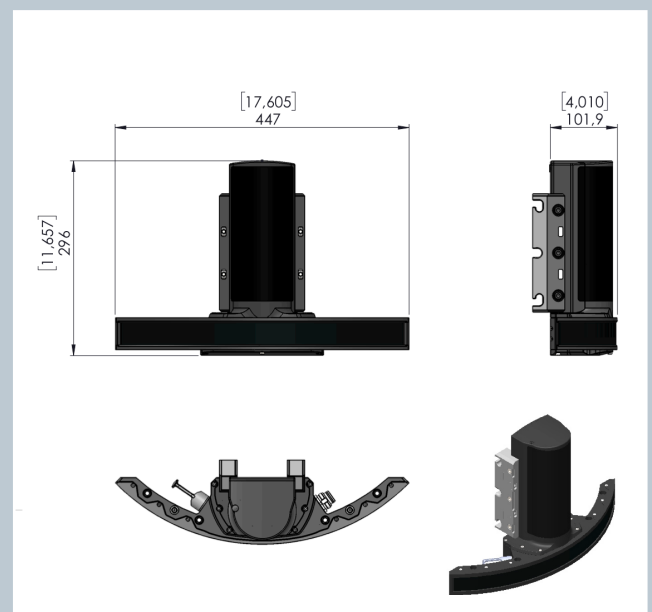

Sonar including bracket (bracket shown in grey)